



AGENDA

WARRENTON PARKS ADVISORY BOARD REGULAR MEETING

April 11th, 2022 – 4:00 P.M.

Warrenton City Commission Chambers – 225 South Main Avenue
Warrenton, OR 97146

1. **CALL TO ORDER**
2. **PLEDGE OF ALLEGIANCE**
3. **CONSENT CALENDAR**
 - a. February 14th Meeting Minutes
4. **REPORTS**
 - a. Warrenton Kids Inc. – Debbie Little
 - b. Public Works Operations – Kyle Sharpsteen
5. **BUSINESS ITEMS**
 - a. Field Use Agreement
 - b. Donation to Library
6. **DISCUSSION ITEMS**
 - a. Park Tours
7. **ADJOURNMENT**

Warrenton City Hall is accessible to the disabled. An interpreter for the hearing impaired may be requested under the terms of ORS 192.630 by contacting Dawne Shaw, City Recorder, at 503-861-0823 at least 48 hours in advance of the meeting so appropriate assistance can be provided.

MINUTES
Warrenton Parks Advisory Board
February 14th, 2022
Warrenton City Hall – Commission Chambers
225 S. Main
Warrenton, OR 97146

Parks Board Members Present: Chairperson Sara Long, Ron Dyer, Anya Schauermann, Brooke Terry, Vice Chair Bert Little.

Park Board Members Absent: Carol Snell, Michelle Murray

Staff Present: Hallie Homolac; Public Works Executive Secretary, Kyle Sharpsteen; Public works Operations Manager

CONSENT CALANDAR

A. Minutes of December 13th Meeting

Vice Chair Bert Little made the motion to approve the minutes of the December 13th meeting. Board member Ron Dyer seconded the motion, and all board members were in favor.

REPORTS

Warrenton Kids Inc. – Debbie Little reported to the board that baseball tryouts were taking place the following weekend. Warrenton Kids Inc. ordered fertilizer and seeds for volunteers to start field maintenance in the next two weeks. Debbie also reported that the City of Astoria Parks Department is not having a program due to lack of staffing and funding, so Warrenton Kids Inc. will work out a schedule for upcoming games and send it to the Public Works Department.

Public Works Operations – Kyle Sharpsteen reported to the board that repairs were made out at the Carruthers Park restroom door. Public Works has also recently hired a part time seasonal employee that will be here through June. Kyle brought up the park lighting project and questioned what the parks board wants as far as lighting goes, Chairperson Long expressed that the board would like the lights to look as good as possible, but vandalism is the primary concern

BUSINESS ITEMS

The Parks Board reviewed the agenda item of the proposed Hammond signs and were well received by the board. Chairperson Long stated that they look excellent and appreciates the acknowledgement of Hammond as a separate entity. Brooke suggested the Welcome to Hammond portion be moved to the top of the sign, and the rest of the board agreed with her suggestion. Ron Dyer made the motion to approve the Hammond

MINUTES
Warrenton Parks Advisory Board
February 14th, 2022
Warrenton City Hall – Commission Chambers
225 S. Main
Warrenton, OR 97146

sign with the suggested revision of putting the Welcome to Hammond at the top of the sign as per Brookes suggestion. Vice Chair Bert Little seconded the motion, and all board members were in favor.

Bob Zappone attended the Parks Board Meeting over Zoom to request a memorial bench application out at Seafarers park for his son Zach. Mr. Zappone is aware of the current complications for getting a bench but is seeking approval for his application and assured the board his understanding of the bench possibly having to be removed for future developments out in Hammond. Kyle pointed out the spot that is suggested in the application is on Clatsop County property. Mr. Zappone responded that he would like the bench to have a riverfront view but is not particular on the location. Chairperson Long made the motion to approve the application pending on the bench location, and all board members were in favor.

DISCUSSION ITEMS

Mr. Widdicombe was present at the parks board meeting and expressed his disappointment in the road maintenance through Seafarers park. Mr. Widdicombe also expressed the amount of people that visit Seafarers park daily and believes it to be a major tourist destination. He suggested the City gets a measuring machine to see how many people visit the park and charge a visitation fee. Chairperson Long explained to Mr. Widdicombe that tourism isn't as important to the board as community outreach and directed him to our parks master plan to view the priority projects.

Commissioner Newton mentioned to the board that the Kiwanis Club is offering a fifty-thousand-dollar grant to put their logo on a splash pad in a local park and would like to potentially apply for a grant to place the splash pad at Quincy Robinson park. The parks board expressed concerns of funding for future maintenance and the filtration system that would be needed

Chairperson Long introduced the new board members and suggested coordinating with Public Works to schedule a tour of the parks for the new members. Chairperson Long also mentioned an upcoming public meeting training opportunity and will notify parks board members when it becomes available to attend.

There being no further business, Chairperson Long adjourned the meeting at 5:30 p.m.

Next regular meeting is scheduled for April 11th, at 4:00 p.m.

MINUTES
Warrenton Parks Advisory Board
February 14th, 2022
Warrenton City Hall – Commission Chambers
225 S. Main
Warrenton, OR 97146

Approved



Sara Long, Chair

Attest



Kyle Sharpsteen, Operations Manager



18240 NORTH BANK ROAD - ROSEBURG, OR 97470
 (541) 496-3541 FAX (541) 496-0803

PRELIMINARY

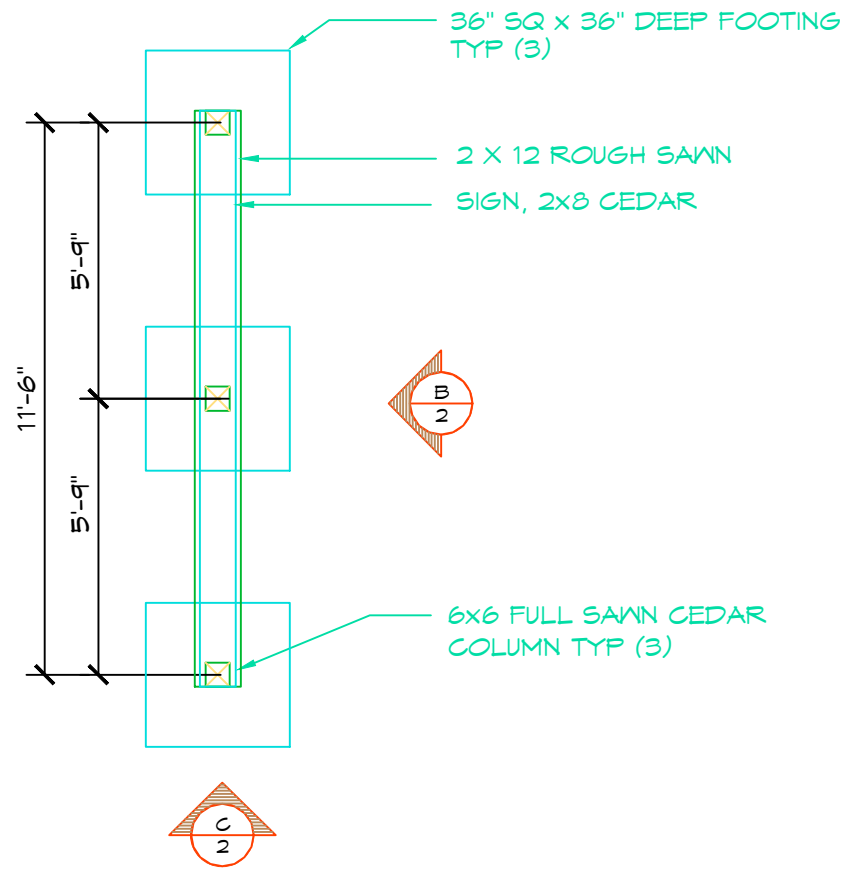
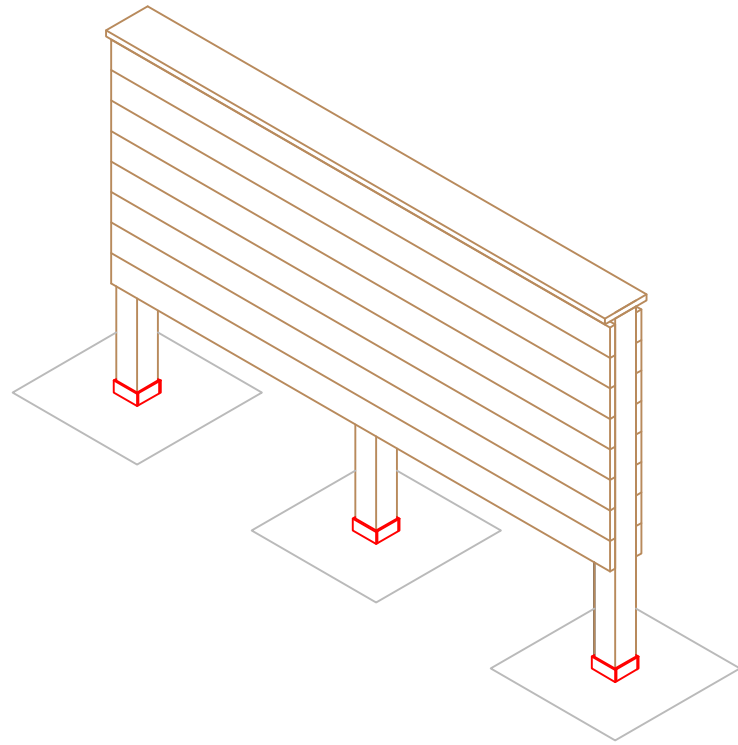

1 FLOOR PLAN
 SCALE: 1/4" = 1'-0"

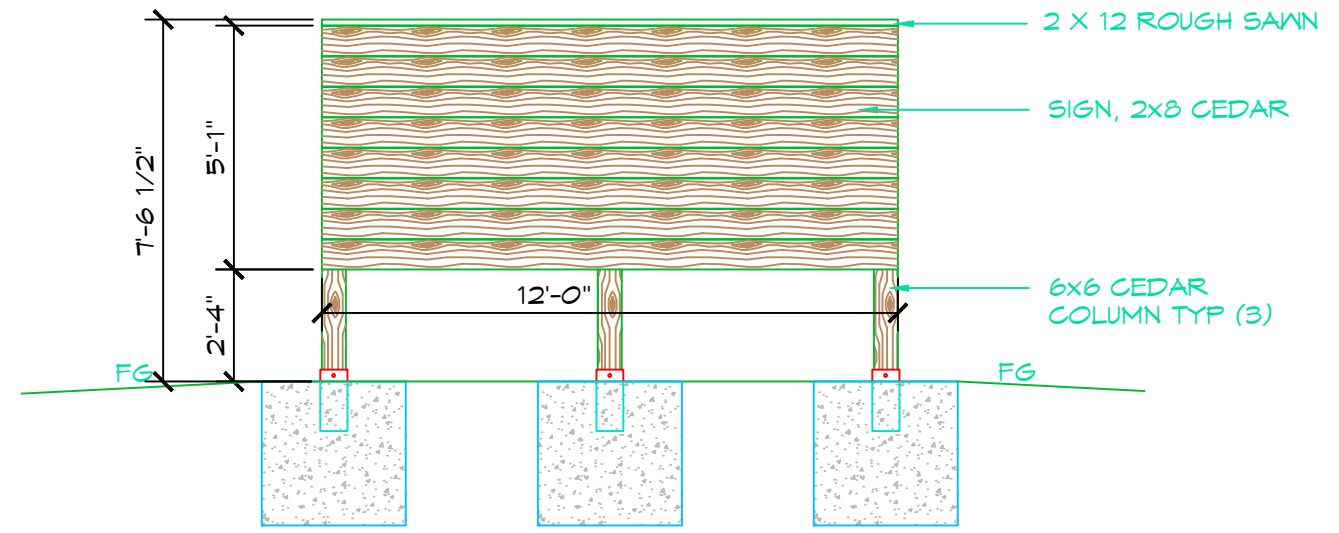
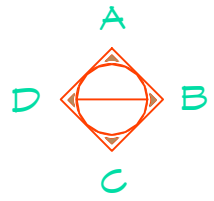

B ELEVATION VIEW
 SCALE: 1/4" = 1'-0"

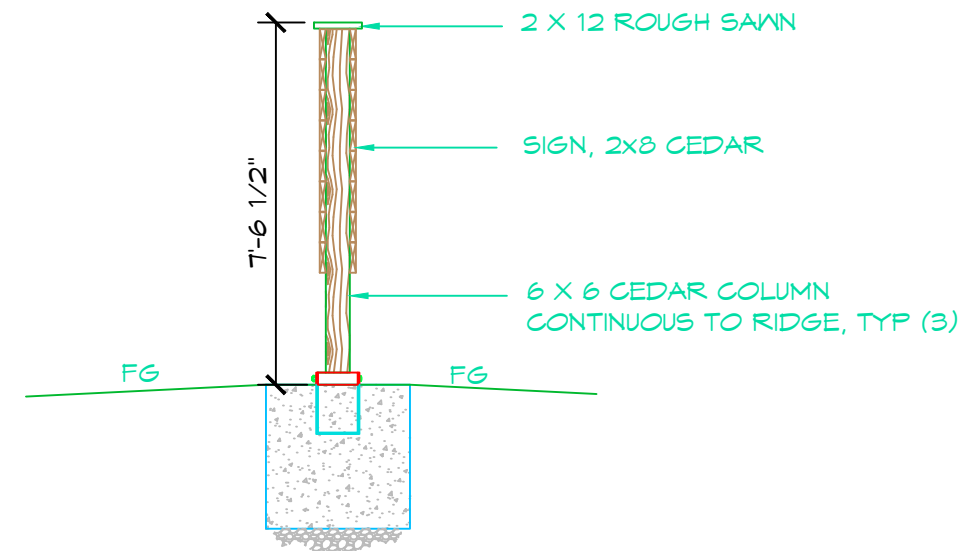

C ELEVATION VIEW
 SCALE: 1/4" = 1'-0"

© 2015 ROMTEC, INC. ALL RIGHTS RESERVED. THESE PLANS AND DRAWINGS MAY NOT BE REPRODUCED, ADAPTED OR FURTHER DISTRIBUTED, AND NO BUILDINGS MAY BE CONSTRUCTED FROM THESE PLANS, WITHOUT THE WRITTEN PERMISSION OF ROMTEC, INC.

PROJECT: 3110 THREE POST TIMBER KIOSK-NO ROOF PROJECT

PROJECT#:	.	
MODEL#:	3110	
DATE:	XX/XX/15	
REVISIONS		
REV.	DATE	BY
DRAWN BY:	TH	

SHEET TITLE: FLOOR PLAN AND ELEVATIONS

SHEET NO.

1